

# Programma "4x4" Contenitori con struttura in alluminio / Storage units with structure in aluminium

## Esploso / Exploded view

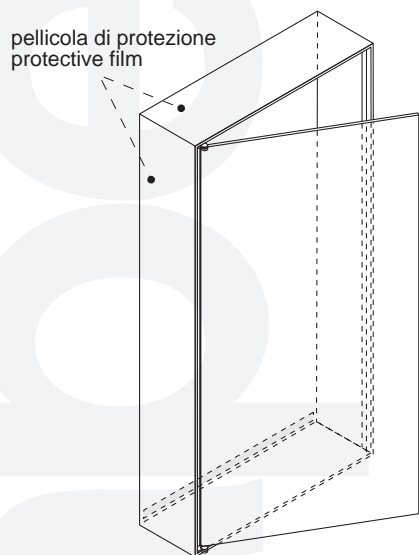

Guida/Rail



Ripiani-Quantità variabile  
Shelves-Variable quantity



Maniglia/Handle



4 Supporti per ripiano  
4 Shelfe Support



a

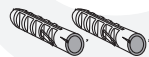

b



c



## Strumenti / Tools

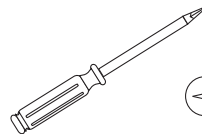
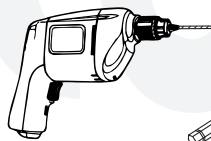

## Elementi / Elements:

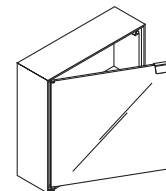

A4X4289  
40x40

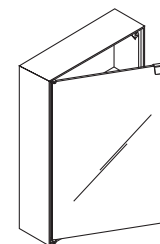

A4X4292  
40x60

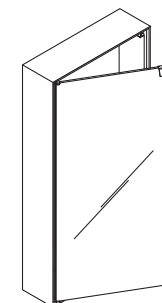

A4X4290  
40x80

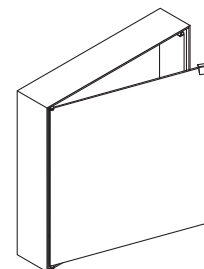

A4X4293  
60x60

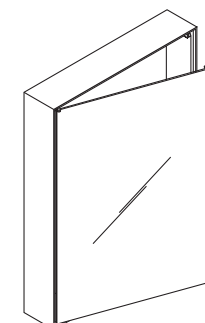

A4X4290H  
60x80

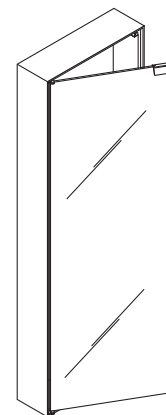

A4X4291  
40x120

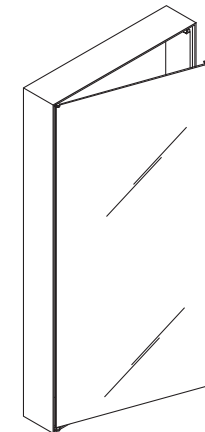

A4X4291H  
60x120

# Programma "4x4" Contenitori con struttura in alluminio / Storage units with structure in aluminium

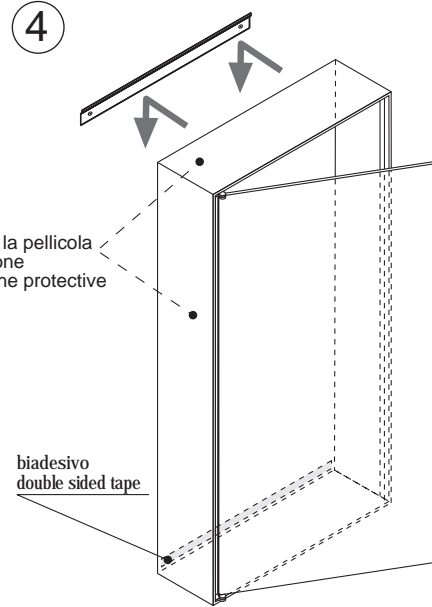
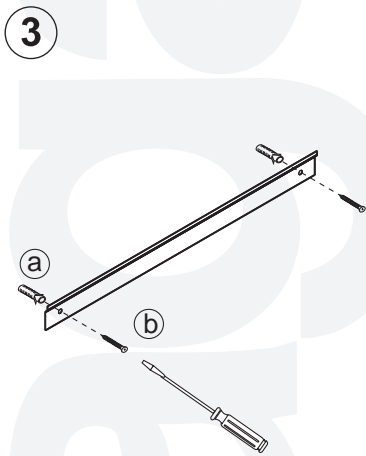
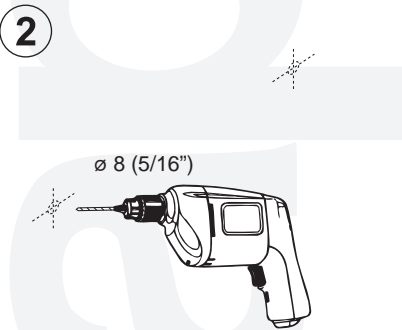
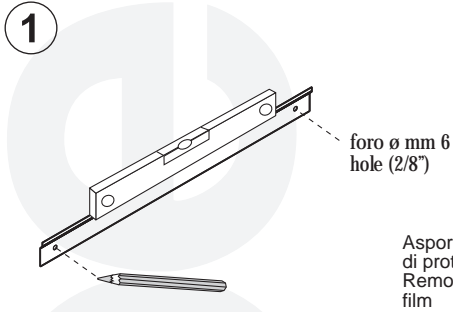

Togliere la protezione del biadesivo prima di posizionare il mobile. Remove the protection of the double sided tape before positioning the storage units.

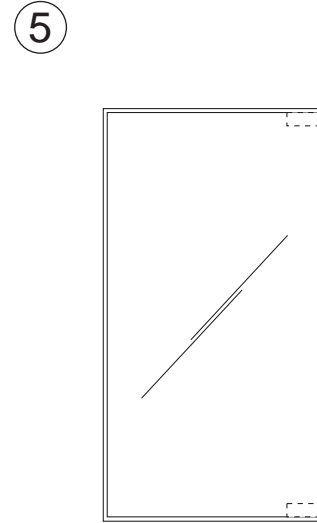
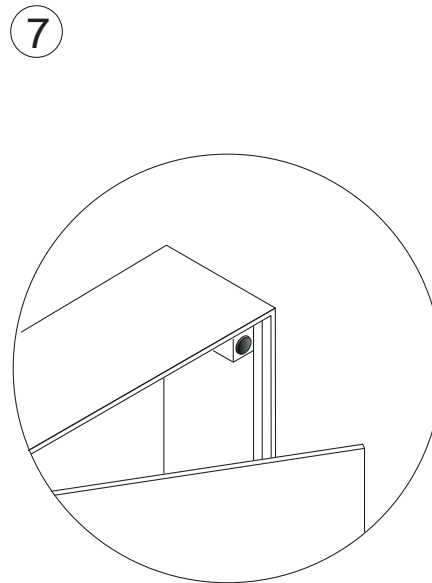

Definire la posizione della maniglia (in alto o in basso). Define the position of the handle (on top or on the bottom).

8 Particolare maniglia / *Detail handle*

*Prima di applicare la maniglia sgrassare e pulire con cura la superficie di incollaggio*  
*Please clean and degrease carefully the mirror surface before glueing the handle*

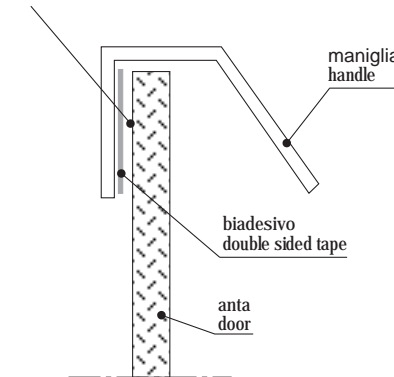

Posizionare la maniglia allineata al bordo dell'anta. Position the handle aligned with the door's edge.

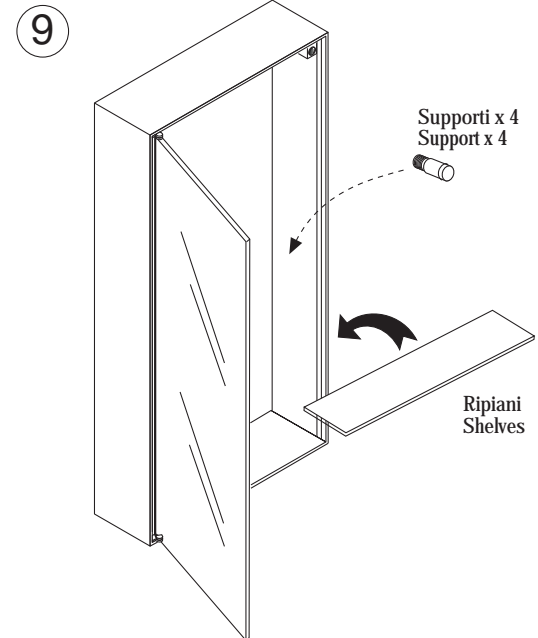
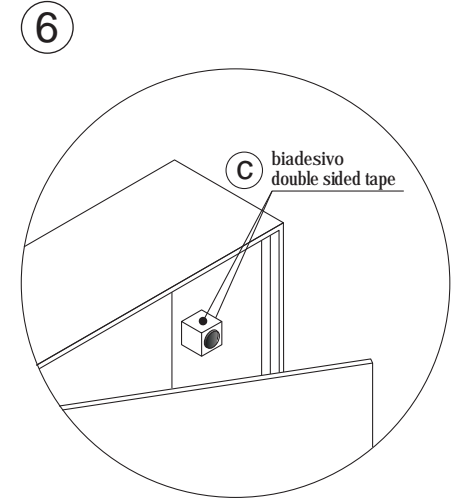

# Programma "4x4" Incasso Contenitori / Built-in Storage units.

## Articoli/ Components

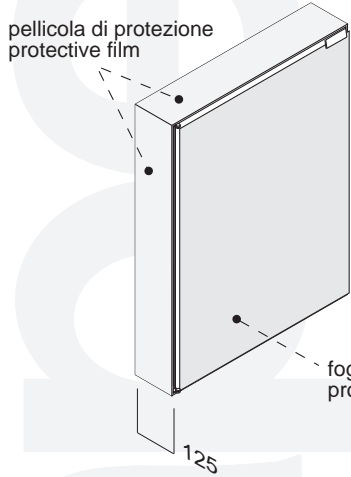

Fascette preforate  
Pre-drilled ties

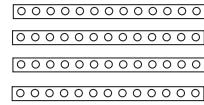

Viti autoperforanti 3,5x13  
self-drilling screw

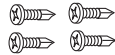

## Strumenti / Tools

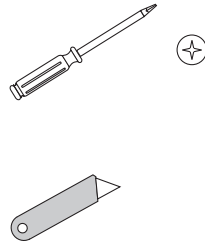

## ② Fissaggio ancoraggi al fianco/Fixing of the bracing alongside

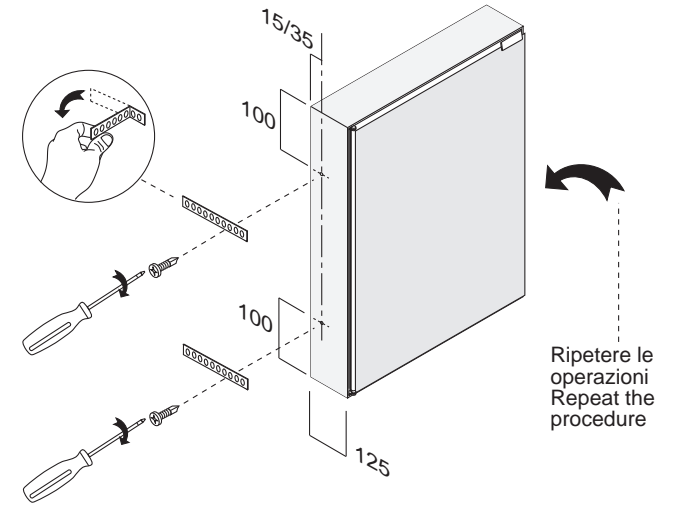
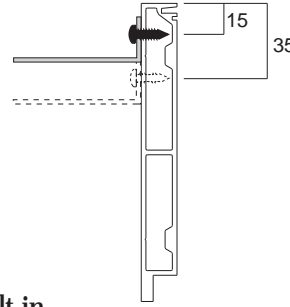

## ① Opere di muratura Masonry

testimoni di intonaco  
plaster

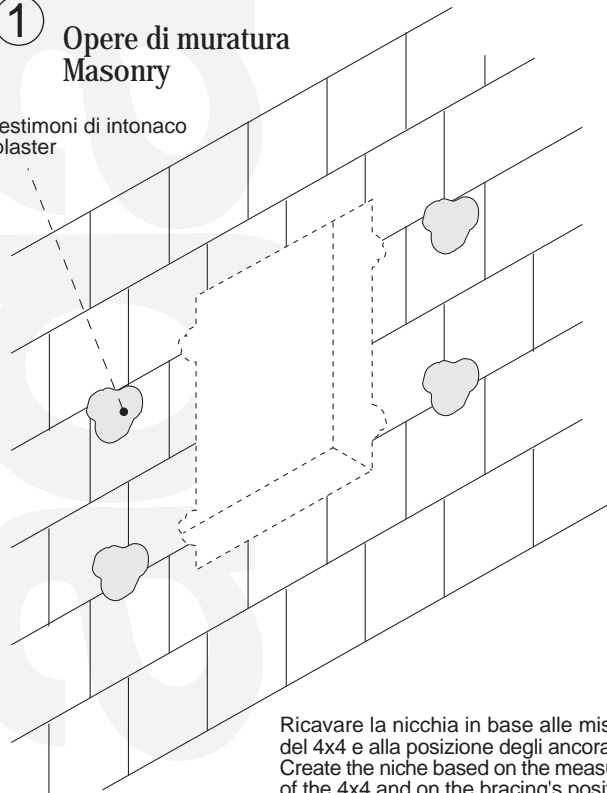

## Semincasso / Semi-built-in

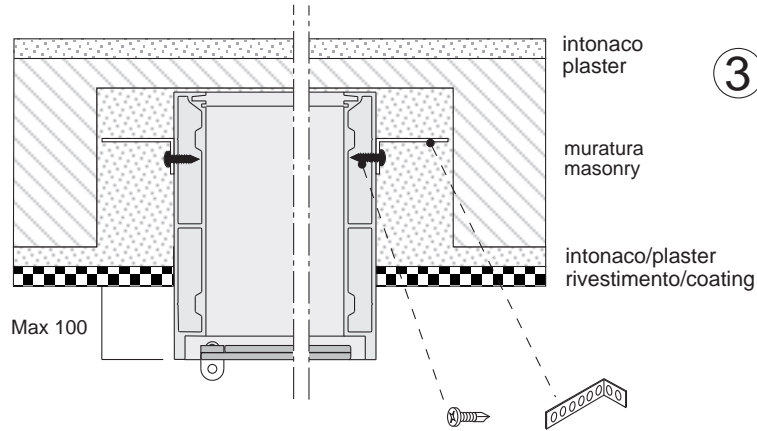

## ③ Inserire e bloccare il contenitore con malta rapida o schiuma poliuretanic. Insert and block the container with rapid mortar or polyurethane foam

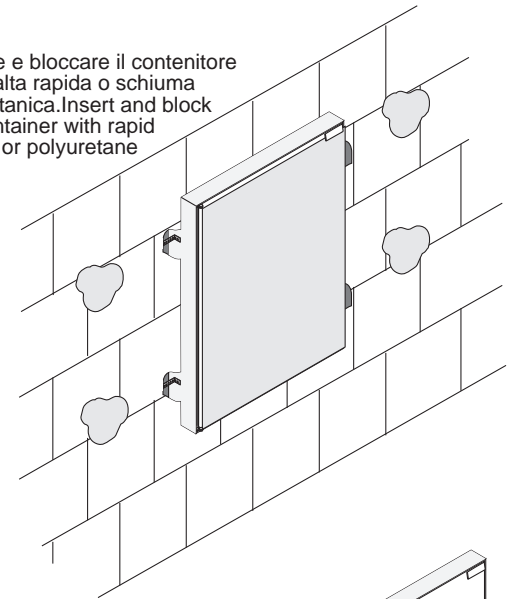

## Incasso totale / Built-in

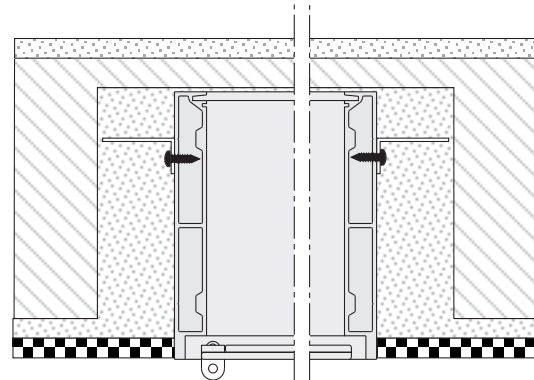

## ④ Terminata l'applicazione del rivestimento incidere delicatamente per asportare la pellicola eccedente. Finished the coating, incise carefully to remove the film in excess.

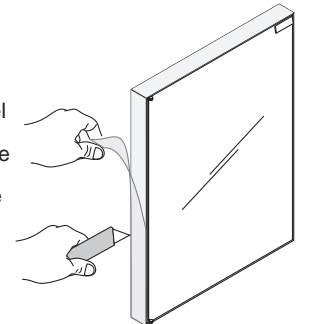

Ricavare la nicchia in base alle misure del 4x4 e alla posizione degli ancoraggi.  
Create the niche based on the measures of the 4x4 and on the bracing's position.