

# AVAS911 "VIEQUES" vasca in metallo / metal bathtub

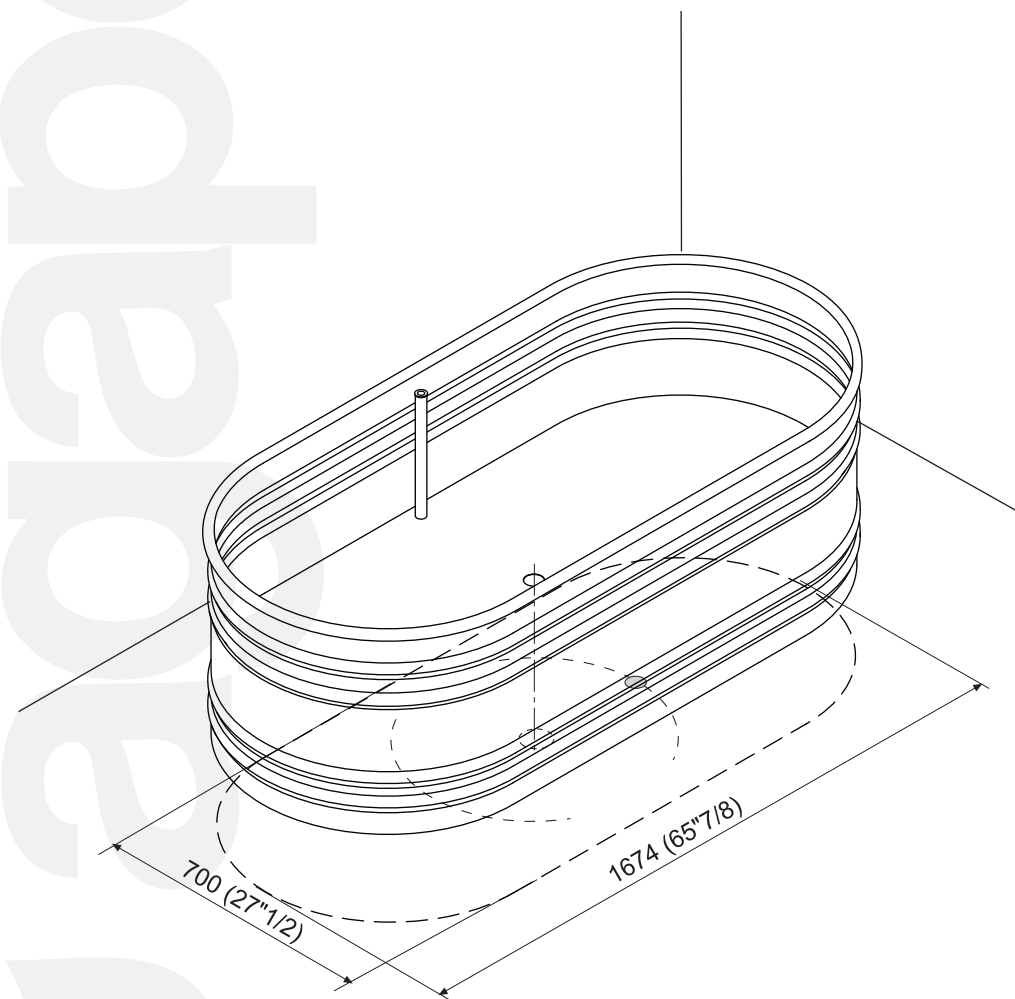

**Attenzione:** evitare di trascinare la vasca sul pavimento senza interporre un panno, per evitare di intaccare la verniciatura del bordo.

**Attention:** do not drag the bathtub over the floor without placing a cloth between bathtub and floor in order to avoid scratching of the edge's varnish.

La vasca "Vieques" deve essere installata su un pavimento perfettamente in piano e non può essere incassata.

Predisporre l'impianto di scarico a pavimento con tubo terminale diametro 40 mm con OR di tenuta ("tipo Geberit") possibilmente nell'area indicata in figura A a filo del pavimento finito.

Si consiglia, prima di procedere alla siliconatura perimetrale della vasca, di utilizzare la stessa per alcune volte, in modo tale da poterne verificare la corretta installazione e garantire l'assenza di perdite; dopodiché, utilizzando silicone antimuffa per sanitari in colore opportuno, procedere alla siliconatura del bordo inferiore visibile.

The "Vieques" bathtub must be positioned on a flat floor surface. Built-in installation not allowed.

Prepare the sewage mains in the floor, ending with a 40 mm diameter pipe with a sealed OR gasket ("Geberit" type), possibly within the area indicated in figure A on the finished floor level.

Before proceeding to seal the tub around its perimeter, it is advisable to run water in it a few times, so as to check that it is correctly installed and to ensure that there are no leaks. Once this has been done, apply anti-mould silicone of an appropriate colour to seal the visible lower edge.

fig. A

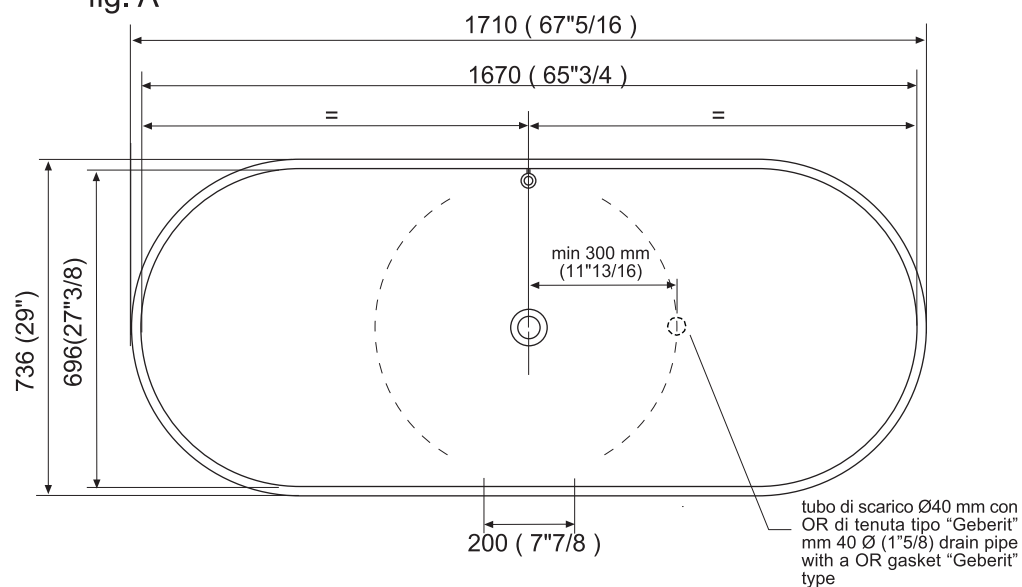

# AVAS911 "VIEQUES" vasca in metallo / metal bathtub

SEZIONE / SECTION

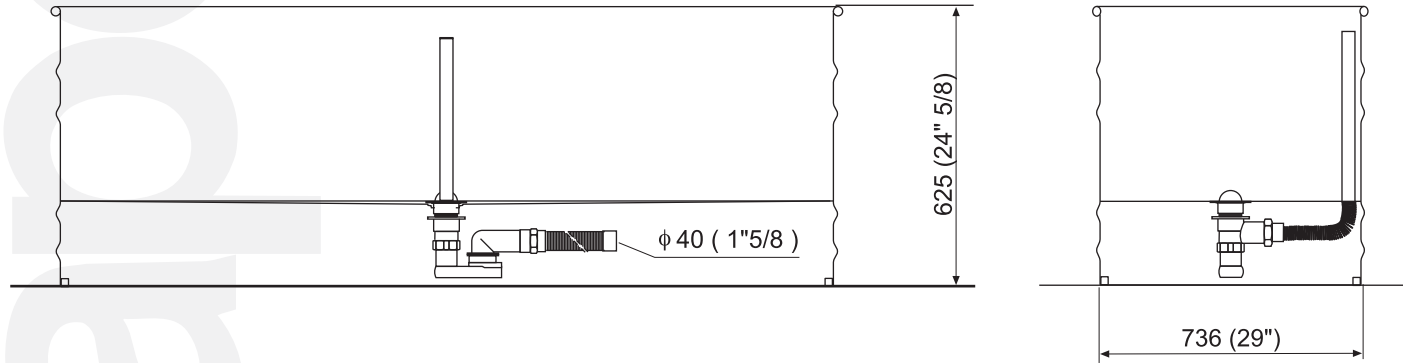

PARTICOLARE PILETTA / DRAIN DETAIL

